

# Isuzu Trooper and Trooper II Hublock Mounting Instructions

## I. REMOVE EXISTING HUBS

Wheel removal may be necessary to access the hublock mounting bolts. Remove the six mounting bolts, retaining ring, and all factory hublock components.

## II. PREPARE WHEEL END

Verify that wheel bearing adjustment is correct and that the lock nut is tightened to the vehicle manufacturer's specification.

## III. INSTALL WARN HUBS AS FOLLOWS

**Note:** Warn Hubs are assembled at the factory with the proper amount of grease. Do not add grease.

1. Separate cap assembly from body assembly.
2. Install gasket and body assembly on wheel end (See Fig.1).
3. Install washers and bolts per chart below:

### Isuzu Trooper I & II, '83-'86

M10x1.5 Socket Head Screw

*Torque to 31-48 N\*m  
(23-35 ft\*lb)*

### Isuzu Trooper II, '87-'93

M10x1.25 Socket Head Screw

*Torque to 34-52 N\*m  
(25-38 ft\*lb)*

4. Install spacer (if required) and **new** retaining ring in groove on axle shaft. Push axle outward from behind the wheel, if necessary. **IMPORTANT:** Verify that the retaining ring is properly seated (See Fig.2).

5. Properly align cap gasket on cap assembly. Place cap assembly on body assembly. Align guide pin in cap to relief in body (See Fig.3). Install and tighten the socket head cap screws to 45-50 in. lb.

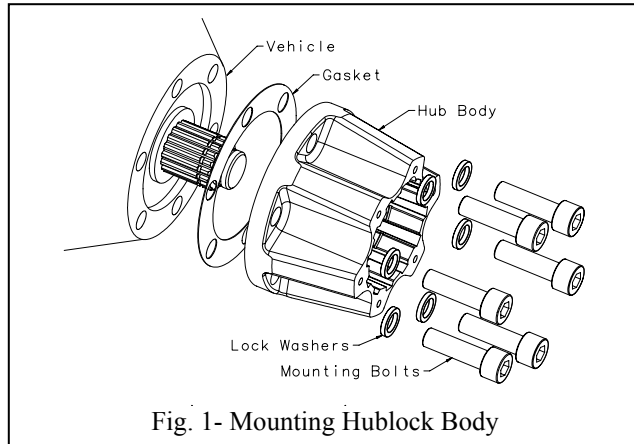

Fig. 1- Mounting Hublock Body

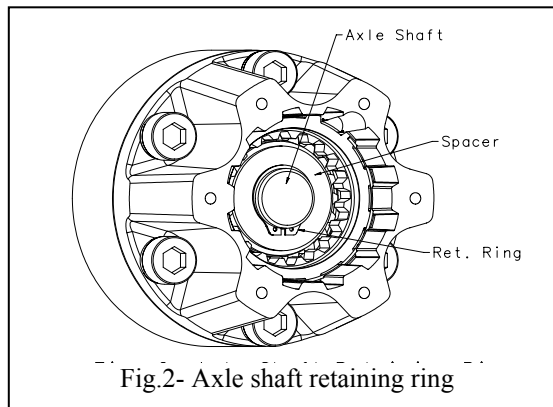

Fig.2- Axle shaft retaining ring

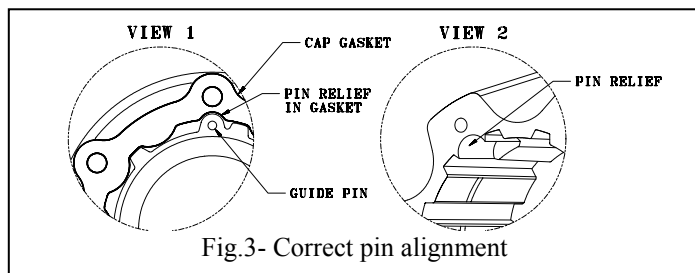

Fig.3- Correct pin alignment

## IV. CHECK FOR PROPER FUNCTION

1. **TO CHECK FOR PROPER ENGAGEMENT**, dial both hubs to LOCK and raise the front left corner of the vehicle off the ground. Spin the lifted tire. The drive line will turn if the hub is engaging properly.
2. **TO CHECK FOR PROPER DISENGAGEMENT**, dial the lifted wheel hub into FREE and spin the lifted wheel. If the drive line does not turn **AND** **NO** ratcheting sound is heard, the hub is disengaging properly. Repeat step 7-8 with the right wheel & hub.

### SERVICE INSTRUCTIONS

Service Kits are available at your retail outlet. Hubs should be serviced at the same interval as the wheel bearings. Remove in reverse order of Installation procedure (III.) Then clean and lightly grease internal working surfaces. **DO NOT PACK THE HUBS WITH GREASE, THE HUBS WILL NOT FUNCTION PROPERLY.**

**Page 2**

**Operation Instructions**

**Warranty**

**WARN ART WORK**

**Are in hard copy only in the print shop**